



ESPECIFICACIONES TÉCNICAS

FRECUENCIA	50Hz
SALIDA MÁXIMA CA.	10kW
SALIDA DE CA. NOMINAL	9kW
TENSIÓN NOMINAL	230V
VELOCIDAD DEL MOTOR	3000rpm
SALIDA CC	12V
DISPLAYMENT	688cc
CAP. TANQUE DE COMBUSTIBLE	25L
CAP. ACIETE LUBRICANTE	1.5L
DIMENSIONES (L*A*H mm)	940*620*700
PESO (Kg)	165

MODELO

GLE12E

MARCA

LOGUS

TIPO DE ALIMENTACIÓN

NAFTA

+54 9 11 4245-9554

WEB www.energiagegroup.com

MAIL energiagegroup@gmail.com

CARACTERÍSTICAS PRINCIPALES



Tablero de conexión



Alternador

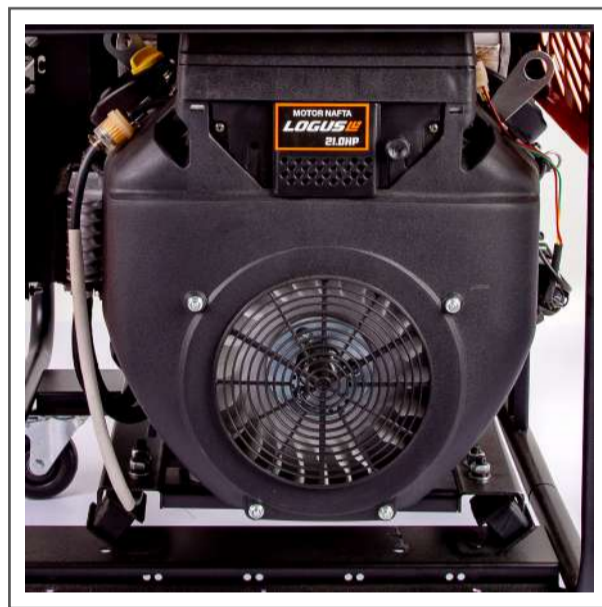

Motor bicilíndrico

DIMENSIONES Y PESO

PESO **165kg**

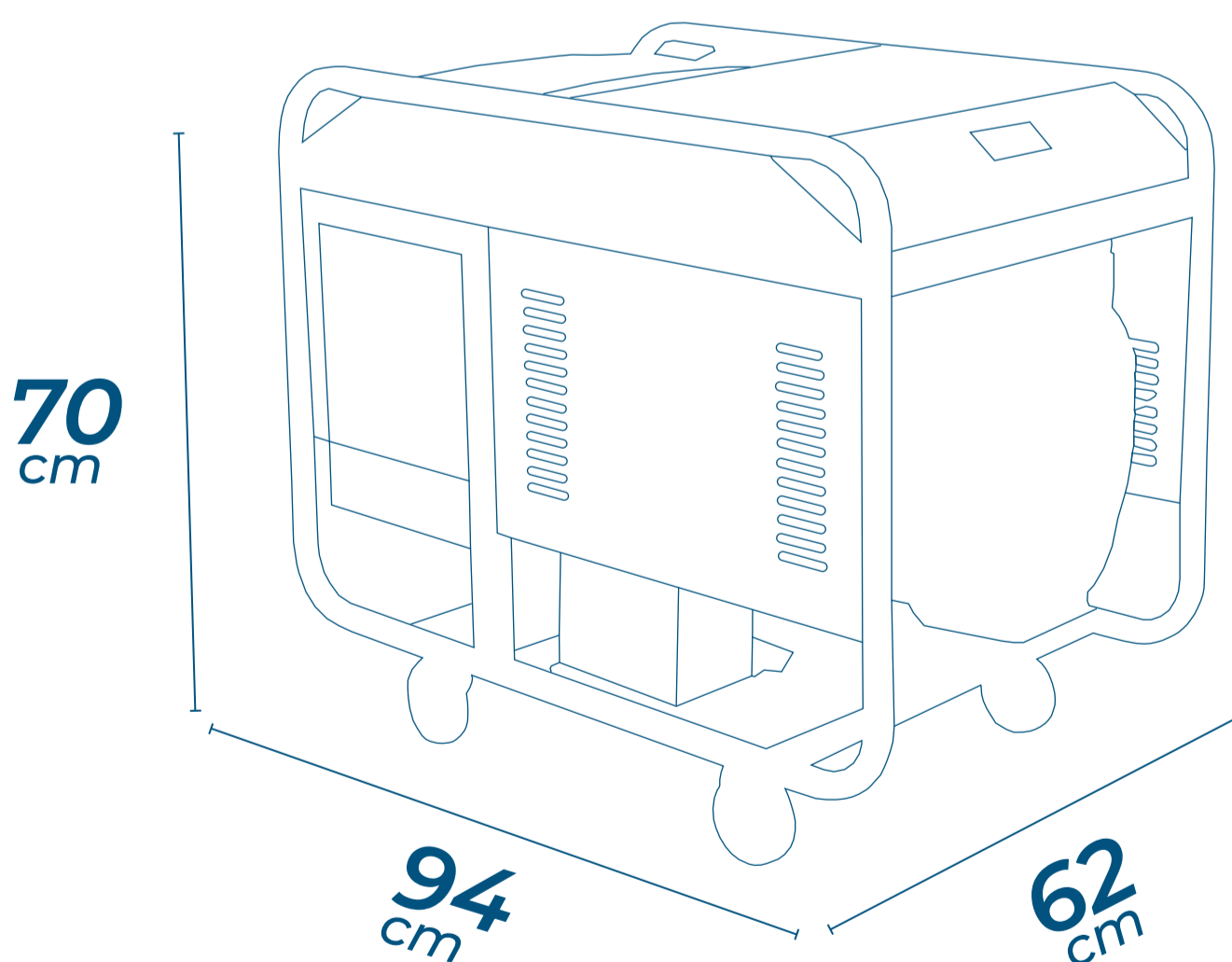

+54 9 11 4245-9554

WEB www.energiagegroup.com

MAIL energiagegroup@gmail.com